

Short Instruction For Use HF Inverter e@syDrive® 4320 (IP 00)

EN



INDUSTRIAL DRIVES





This short instruction for use includes only the essential control functions.

It does not however replace the Sieb & Meyer Hardware Description "Drive Amplifier SD2B / SD2B plus" that have to be downloaded before commissioning:

*- on the SycoTec homepage at the download area under
<https://www.sycotec.eu/en/about-sycotec/downloads2/>
respectively*

*- at Sieb & Meyer under
<https://www.sieb-meyer.com/file-detail.html?item=519>*

► The safety information have to be observed before commissioning!

Content

1.0 Scope of Supply	3
2.0 Connections	3
3.0 Motor	3
3.1 Motor Temperature Sensor	3
3.2 Assignment of the Parameter Sets	4
3.3 Connection choke	4
4.0 DC Power Supply	5
5.0 24 V Logic Supply	5
6.0 Digital and Analog Inputs / Outputs	5
6.1 Digital Inputs	5
6.2 Digital Outputs	6
6.3 Analog Inputs	6
7.0 Example of Remote Control Element	7
8.0 Connecting to the Computer	7
9.0 Activate another Parameters	8
10.0 Load Parameter File	9
11.0 Load Project	10
12.0 Status Display and Error Messages	11
Warranty Conditions	11
CE Declaration of Conformity	11

Distribution:

SycoTec GmbH & Co. KG
Wangener Strasse 78
88299 Leutkirch, Germany
Phone +49 7561 86-0
Fax +49 7561 86-371
info@sycotec.eu
www.sycotec.eu

Manufacturer:

SIEB & MEYER AG
Auf dem Schmaarkamp 21
21339 Lüneburg, Germany
Phone +49 (0)4131 203-0
Fax +49 (0)4131 203-2000
info@sieb-meyer.de
www.sieb-meyer.com



1.0 Scope of Supply

HF Inverter e@syDrive® 4320 (IP 00)
 (Drive System SD2B / device variant 0362171DB)

Material no. 2.001.7554

SycoTec – Short Instruction For Use
 HF Inverter e@syDrive® 4320 (IP 00)

Material no. 2.001.7975

2.0 Connections

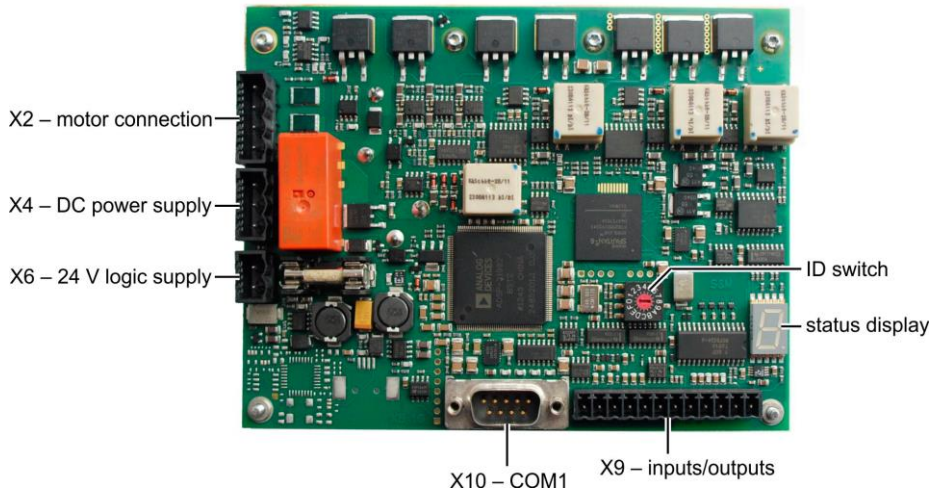

3.0 Motor

Name	I/O	Meaning	Pin
U	0	Motor phase U	X2/U
V	0	Motor phase V	X2/V
W	0	Motor phase W	X2/W
PE		Protective conductor	X2/PE

3.1 Motor Temperature Sensor

Name	I/O	Meaning	Pin
Temp	I	Motor temperature sensor (towards GND)	X9/8
GND	I/O	Ground	X9/7,11,12

3.2 Assignment of the Parameter Sets

Assignment	Parameter set of motor spindle	Remark
P00	4025 AC	
P01	4033 AC	
P02	4033 AC-ST-60	
P03	4033 AC-LN15	
P04	4052 AC	
P05	4015 DC	
P06	4020 DC	
P07	4025 DC-S	
P08	4025 DC-T	
P09	4033 DC	
P10	4033 DC-T	
P15	4015 DC - Choke	Motor spindle must be operated with an upstream choke / external inductance of 220 µH
P16	4020 DC - Choke	
P17	4025 DC-S - Choke	
P18	4025 DC-T - Choke	
P19	4033 DC - Choke	
P20	4033 DC-T - Choke	

3.3 Connection choke

The connection X2 (Motor) of the frequency inverter is connected to connection X1 (Drive) of the choke. The motor phases are connected to X2 (Motor) of the choke.

X1 (Drive)		
Name	Meaning	Pin (Choke)
U	Motor phase U	X1/U
V	Motor phase V	X1/V
W	Motor phase W	X1/W
PE	Protective conductor	X1/⊕

X2 (Motor)		
Name	Meaning	Pin (Choke)
U	Motor phase U	X2/U
V	Motor phase V	X2/V
W	Motor phase W	X2/W
PE	Protective conductor	X2/⊕

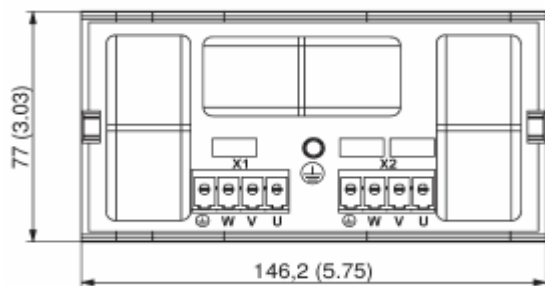

4.0 DC Power Supply

Name	I/O	Meaning	Pin
DC+	I	Main supply +	X4/+
DC-	I	Main supply -	X4/-
PE		Protective conductor	X4/PE

Voltage range: 24 up to 80 V DC, voltage ripple max. 10%

The supply voltage can be adjusted with the drivemaster2-software ("Configuration" -> "Power supply").

Supply voltage (U _{DC})	Chopper threshold (U _{DC})	Overvoltage threshold (U _{DC})
24 V	35 V	40 V
48 V	65 V	70 V
85 V	100 V	110 V

Standard-setting voltage power supply: 48 V

i During braking of high inertia masses and/or when using short braking times the DC main voltage can increase significantly depending on the parameterized supply voltage.
The connected power supply unit must be designed for this voltage.

5.0 24 V Logic Supply

Name	I/O	Meaning	Pin
+24V	I	Logic supply +24 V DC (0.5 A)	X6/+
GNC	I/O	Ground	X6/-

Voltage range: 24 V DC (0.5 A), voltage ripple max. 10%

6.0 Digital and Analog Inputs / Outputs

The functions / assignments of the inputs and outputs can be configured via the drivemaster2 software. By default, the following functions / assignments are set.

6.1 Digital Inputs

Name	I/O	Function / Assignment	Pin
IN0	I	Switch on	X9/1
IN1	I	Operation enable	X9/2
GND	I/O	Ground	X9/7,11,12

IN0 "Switch on" activates the controller, the holding current is applied to the motor spindle. If the controller is active, the motor spindle can be started with IN1 "Operation enable".

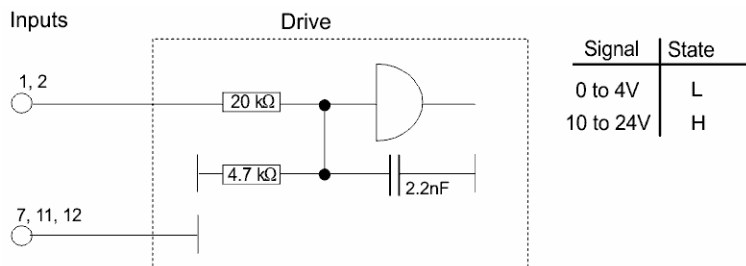

6.2 Digital Outputs

Name	I/O	Function / Assignment	Pin
OUT0	O	Ready type 1	X9/3
OUT1	O	M02 – Message operation enabled	X9/4
OUT2	O	M10 – Ref. value reached	X9/5
GND	I/O	Ground	X9/7,11,12

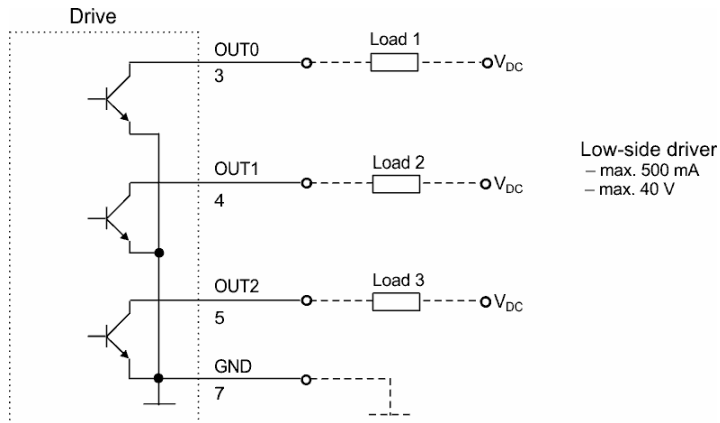

6.3 Analog Inputs

Name	I/O	Function / Assignment	Pin
VCC_10	O	10 V voltage supply for analog input	X9/6
AIN0+	I	+/- 10 V analog input	X9/9
AIN0-	I	Reference point for AIN0+ (bridge with ground)	X9/10
GND	I/O	Ground	X9/7,11,12

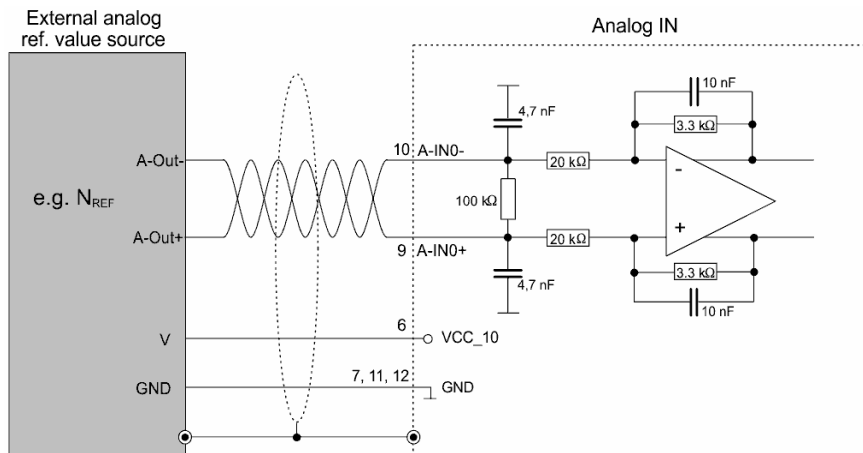

Voltage interface with input voltage range: ± 10 V
 Can also be connected to potentiometer (500 Ohm – 5 kOhm)

7.0 Example of Remote Control Element

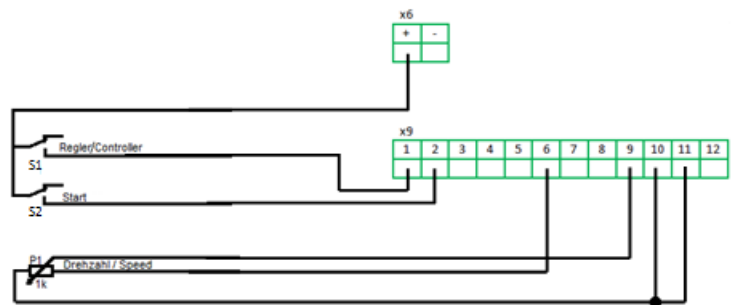

8.0 Connecting to the Computer

Connect the inverter via X10-COM1 interface to the computer.

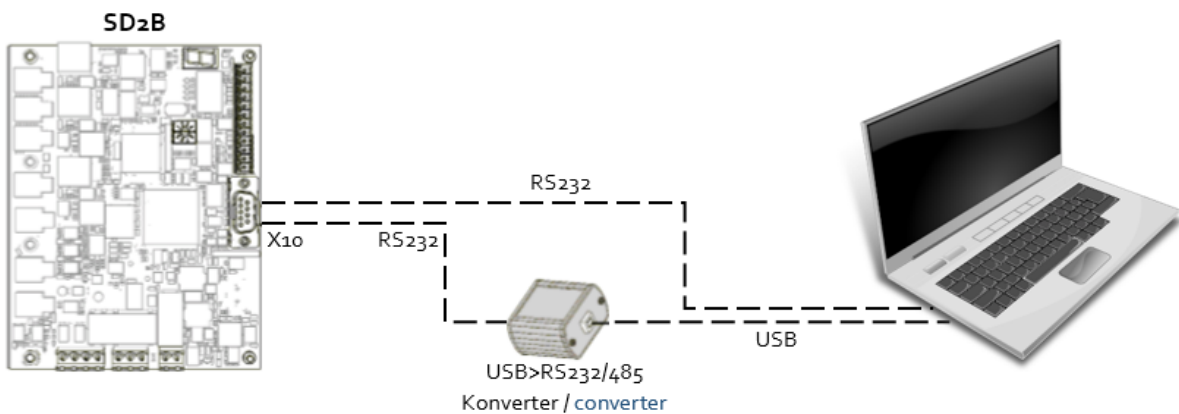

Plug in the inverter. Start drivemaster2-software.

To establish a connection to the device click "Setup connection to the device". Depending on the connection type between the inverter and the PC, set USB (USB>RS232/485 converter 050201) or RS232_RS485 (RS232 cable) for connection type. Select "Search devices + connect".

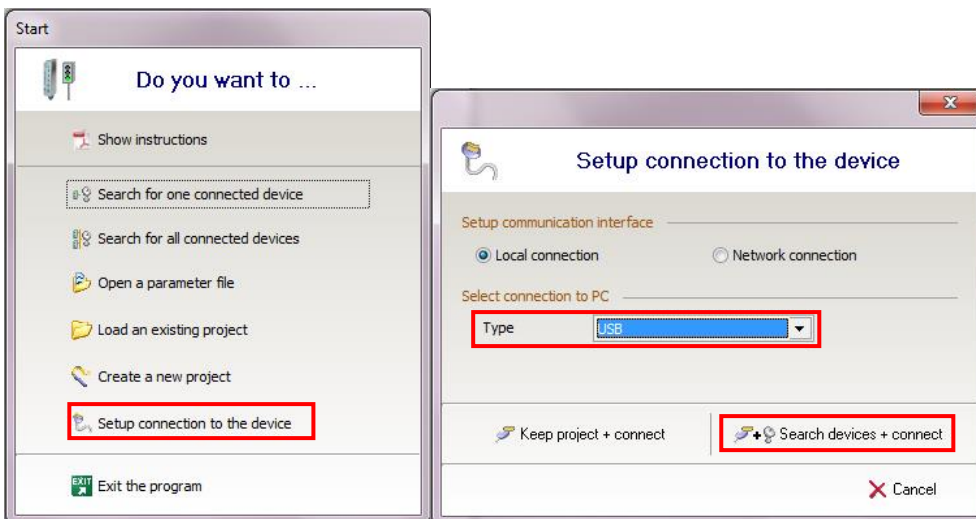

i The pin assignment of the RS232 cable is describes in „Drive System SD2B – Hardware Description“.

9.0 Activate another Parameters

To activate a different parameter file, enter the number (P00 ... Pxx) of the required parameter file and click "Apply".

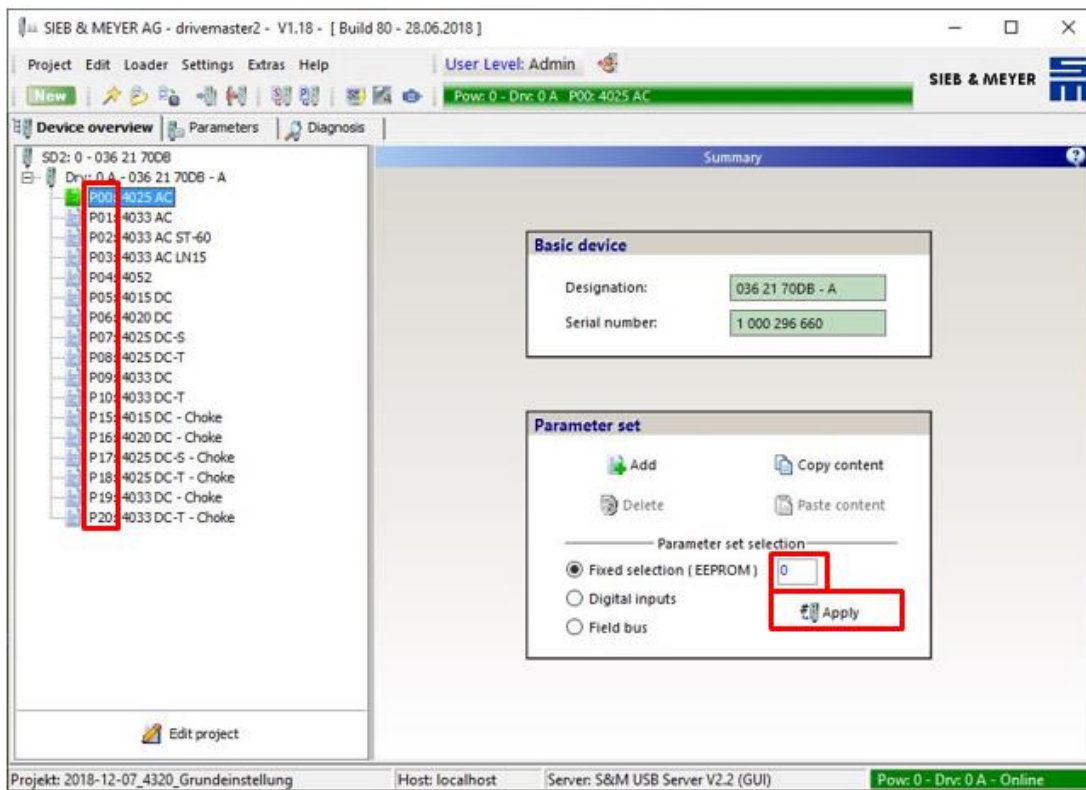

10.0 Load Parameter File

Before opening the parameter file add a new parameter set and / or select the correct position (Pxx).

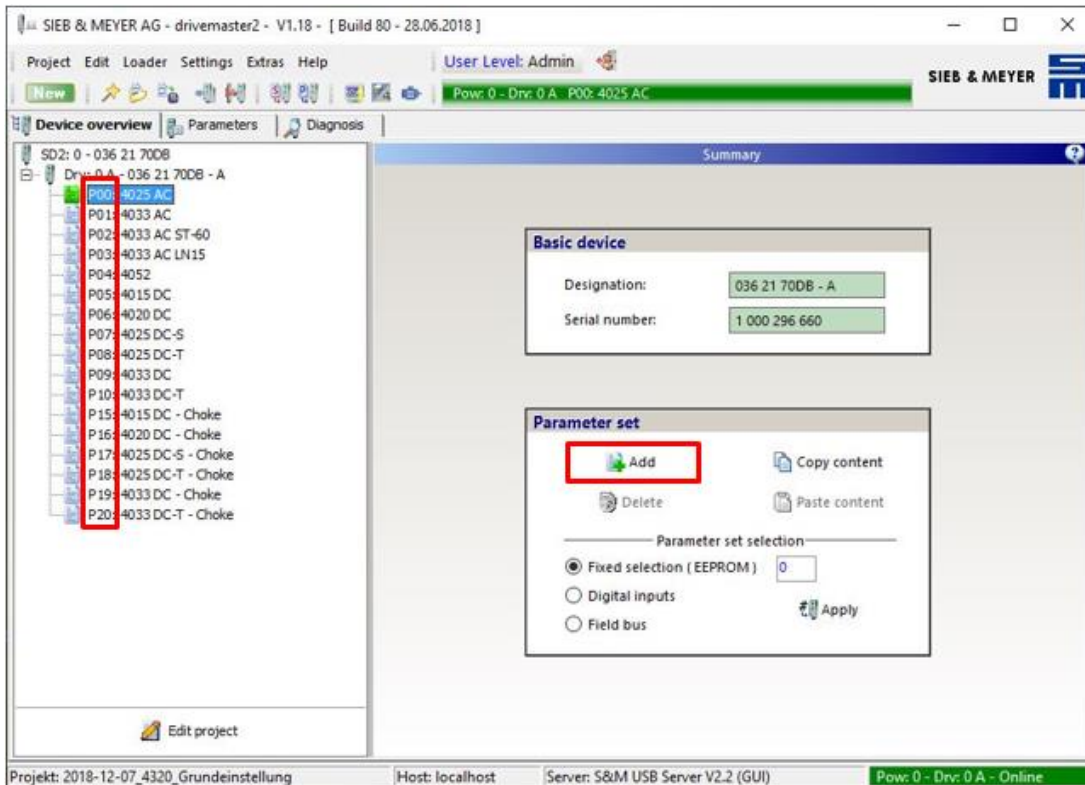

To open a parameter file, click "Open parameters" on the toolbar and select the required parameter file. To write the parameter file into the inverter, click "Write parameter set in drive" on the toolbar.

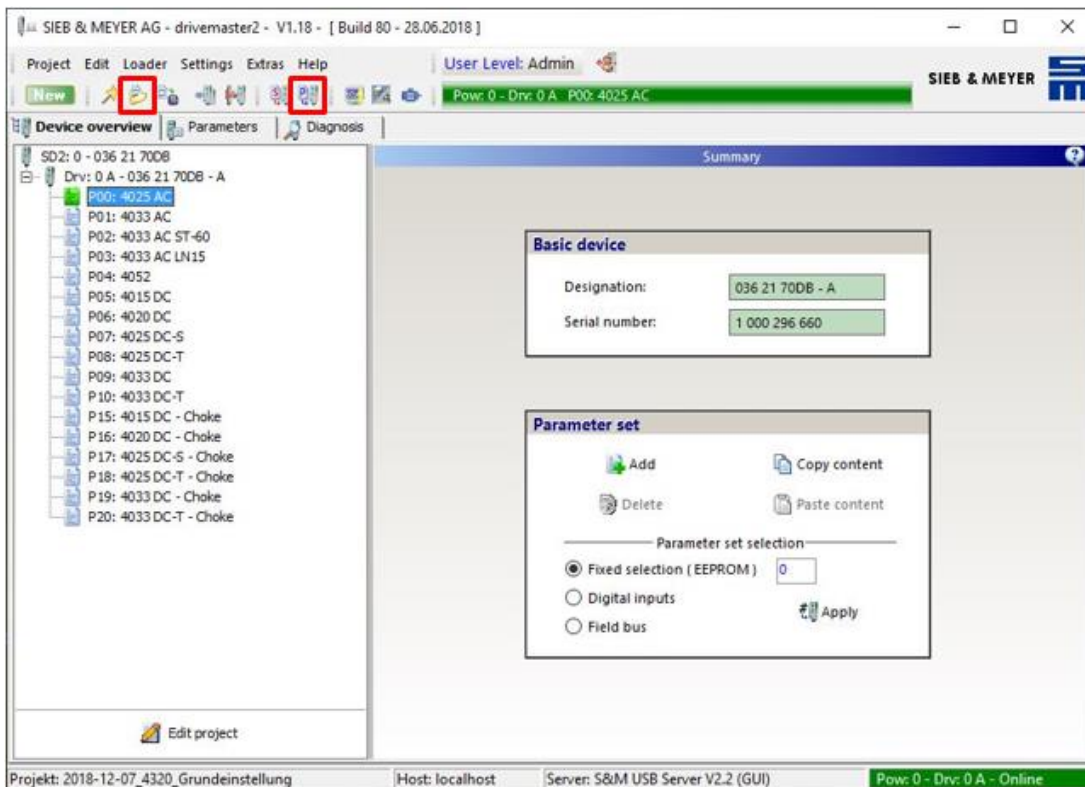

11.0 Load Project

To open a project select "Project" and then "Open project". Select the required project file and click "Open".

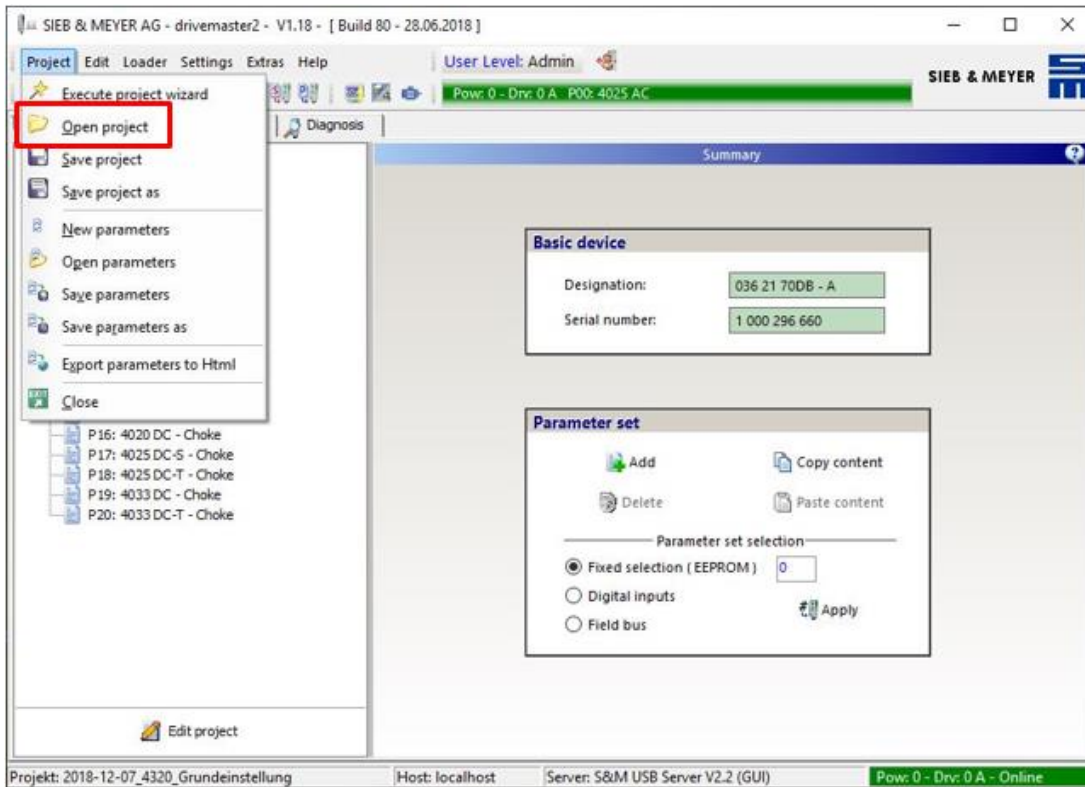

To write the project to the inverter select "Loader" in the menu bar and then "Write project to drives".

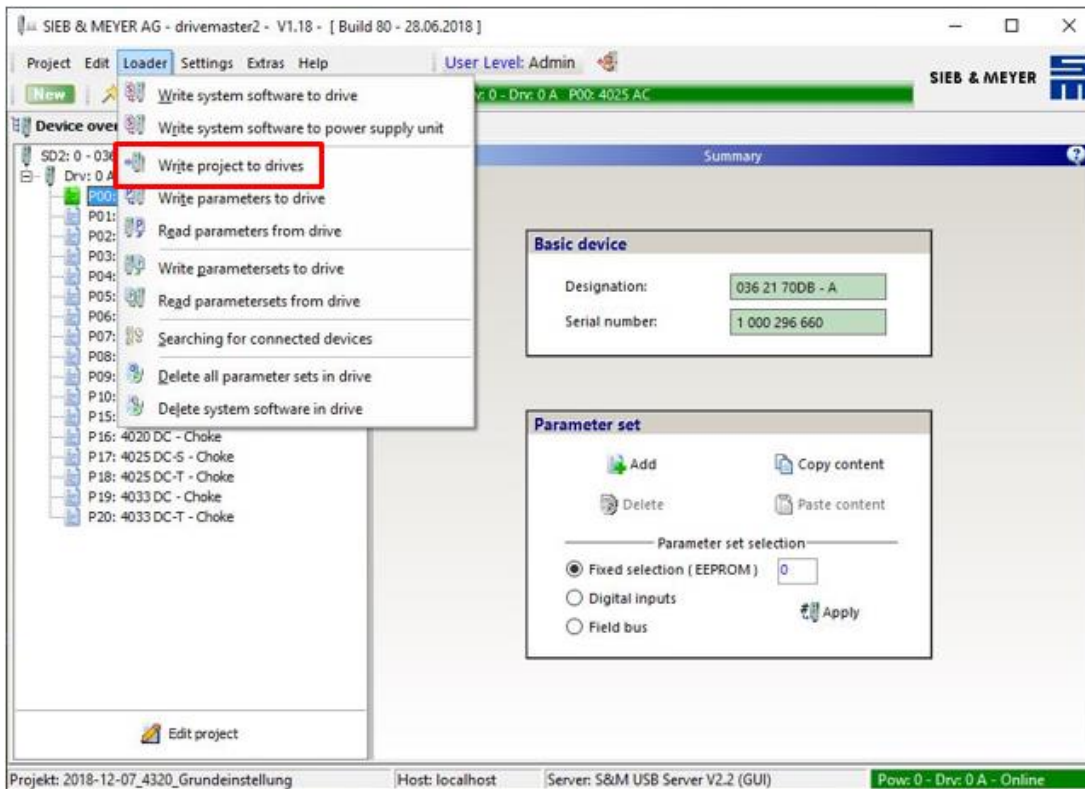

12.0 Status Display and Error Messages

The 7-segment display shows status and error messages.

All messages end with dot behind the last digit.

When the first digit is "E.", there is a permanent error.

Examples:

1.		Startup Message - Controller is in boot loader mode: Display appears short-time when the device is booted and when the system software is loaded.
2.		Ready to switch on - Controller is switched off - No error
3.		Controller active - Controller is switched on - No error
4.		Error Message - Controller is switched off due to error E40 - The error is not present anymore
5.		Persistent Error Message - Controller is switched off due to error E40 - The error is still present

Warranty Conditions

Under current SycoTec delivery and payment conditions, SycoTec undertakes warranty for satisfactory function and freedom from faults in material and manufacture for a period of 12 months from the date of sale certified by the vendor.

In the event of justifiable complaints, SycoTec shall supply spare parts or carry out repairs free of charge under warranty. SycoTec accepts no liability for defects and their consequences which have arisen or could have arisen as a result of natural wear and tear, improper handling, cleaning or maintenance, non-compliance with the maintenance, operating or connecting instructions, corrosion, impurities in the air supply or chemical or electrical influences which are unusual or not admissible in accordance with SycoTec's standards. The warranty claims shall become null and void if defects or their consequences can be attributed to interventions in or modifications to the product. Warranty claims can only be validated if they are notified immediately in writing to SycoTec.

A copy invoice or delivery note clearly showing the manufacture number shall be attached if products are returned.

CE Declaration of Conformity

The CE Declaration of conformity may be requested or downloaded from www.sycotec.eu.

2.001.7975 / 2018-12

(DE = original)

INDUSTRIAL DRIVES

SycoTec GmbH & Co. KG
Wangener Strasse 78
88299 Leutkirch
Germany

Phone +49 7561 86-0
Fax +49 7561 86-371
info@sycotec.eu
www.sycotec.eu

